

P1 Plug Straight

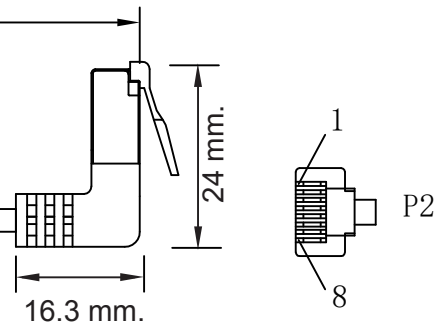

P2 Plug 90° Outer

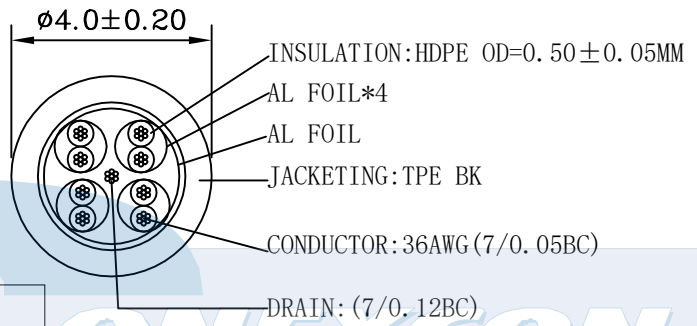

WIRE CONNECTION

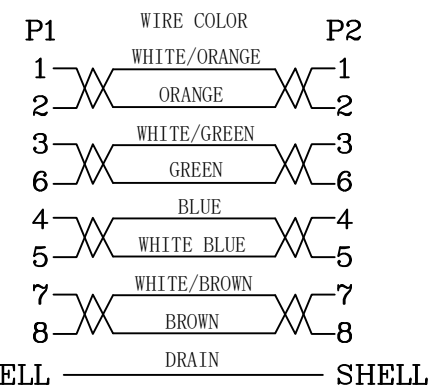

Part Number:

9610 - XXX - P - G

1 2 3 4

1. Serie

2. (XXX) Length in Cm.

3. (P) Cable Type

- P = 0. UTP
- P = 1. SSTP

4. (G) Colour

- G = 1. Grey

REMARK:

1. CABLE: CAT7 SSTP CABLE [1P*36AWG(7/0.05BC)+AL]*4+ DRAIN(7/0.12BC)+AL+TPE.OD:4.0±0.20MM.
2. CONN. :P1 P2 8P8C PLUG, SHORT BODY, , PIN GOLD PLATED 1U", GOLD PLATED SHELL
3. ALL HOOD: MOLDED PVC .
4. PACKING: EACH CABLE IN POLY-BAG.

NOTES:

1. ELECTRICAL TEST: 100% OPEN, SHORT & MISS WIRE TEST.
2. INSULATOR RESISTANCE: 5M OHMS MIN.
3. HI-POT: DC 300V 0.01sec.
4. ALL MATERIAL FIT ROHS STANDARD.

TOLERANCE						
	INCHES	M/M				
. X	. 015	. 30	UNIT	MM		
. XX	. 010	. 10	SHEET	1/2		
. XXX	. 005	. 05	DATE	17. 10. 30		
DRAWN BY	Peter		TITLE			
CHECK BY			8P8C PLUG/ 8P8C PLUG			
APPD BY			PART NO.			
			9610-XXX-P-G			