

**Part Number:**

**9609 - XXX - P - G**

1            2            3            4

**1. Serie**

**2. (XXX) Length in Cm,**

**3. (P) Cable Type**

- P = 0. UTP
- P = 1. SSTP

**4. (G) Colour**

- G = 1. Grey

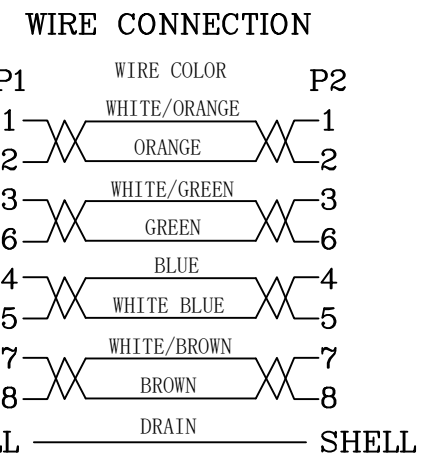

- NOTES:
- 1.ELECTRICAL TEST:100% OPEN,SHORT & MISS WIRE TEST.
  - 2.INSULATOR RESISTANCE: 5M OHMS MIN.
  - 3.HI-POT: DC 300V 0.01sec.
  4. ALL MATERIAL FIT ROHS STANDARD.

**REMARK:**

- 1.CABLE: CAT7 SSTP CABLE [1P\*36AWG(7/0.05BC)+AL]\*4+ DRAIN(7/0.12BC)+AL+TPE.OD:4.0±0.20MM.
2. CONN. :P1 P2 8P8C PLUG, SHORT BODY, , PIN GOLD PLATED 1U", GOLD PLATED SHELL
3. ALL HOOD: MOLDED PVC .
- 4.PACKING: EACH CABLE IN POLY-BAG.

TOLERANCE			ONEXCON		REV		A	
INCHES	M/M	SCALE						
. X	.015	.30	UNIT	MM	DWG NO.	REV	A	
. XX	.010	.10	SHEET	1/2				
. XXX	.005	.05	DATE	17. 10. 30				
DRAWN BY	Peter		TITLE	8P8C PLUG/ 8P8C PLUG				
CHECK BY			PART NO.	9609-XXX-P-G				
APPD BY								