

# CRIMP TERMINAL



## 3979 SERIES. 3.96 (0.156")/ 5.00 (0.197")/ 5.08 (0.200")/7.50 (0.295")mm. Pitch housing.

### General Features

- Accommodates wire range AWG 18 through 26
- Use in housing 3.96 mm pitch 3940 series; housing 5.00 mm 5000 series, 5.08 mm 5080 and 7.50 mm 7500 series
- Flex contact with tin plated locking lance
- Maximum insulation diameter 2.48 mm (0.098")

### Materials

- Contact: Phosphor bronze tin pre-plated
- Operating temperature -40°C to +105°C

### Electrical Features

- Current rating: < 7 A
- Contact resistance: < 20 mΩ
- 

### Mechanical Features

- Durability: 25 cycles
- Wire pull-out force:
  - 10.00 Kgf 18 AWG
  - 8.00 Kgf 20 AWG
  - 6.30 Kgf 22 AWG
  - 4.50 Kgf 24 AWG
  - 2.70 Kgf 26 AWG

### Dimensional Information

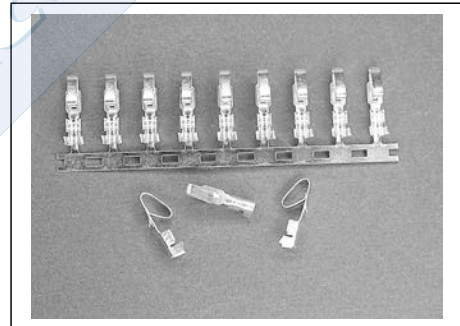
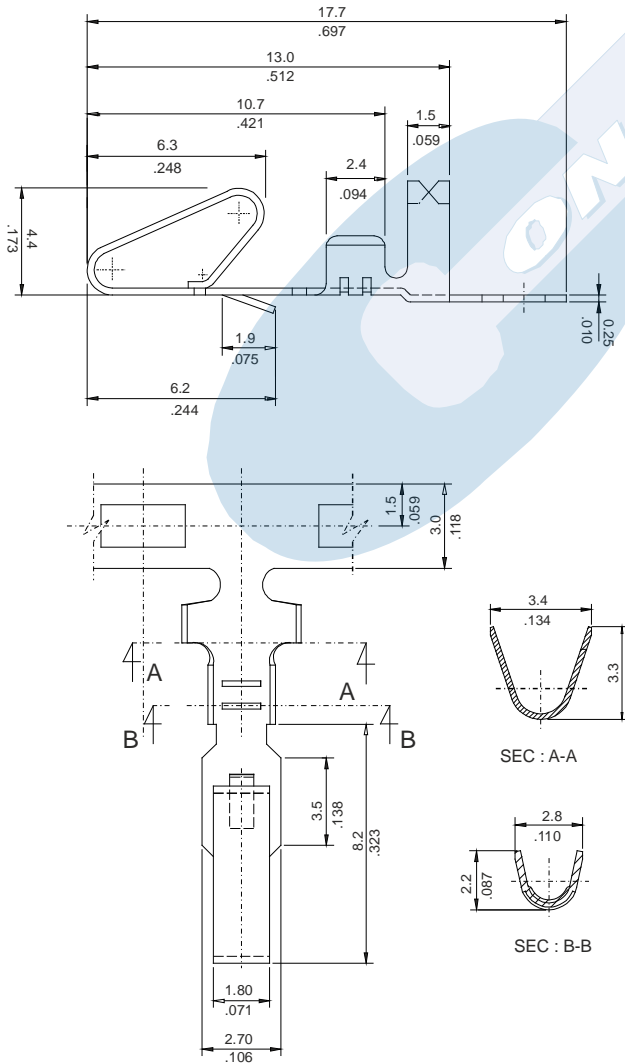

**3979 - T- 00- E**  
1 2

#### 1. Terminal Serie

#### 2. (T) Contact Plating

- T = 2. Tin plated

#### 2. (E) Packing Options

- E = 0. Chain
- E = 1. Loose Piece