

# CRIMP FEMALE TERMINAL



## 3524 SERIES. 4.00 mm. (0.157") Pitch.

### General Features

- Accommodates wire range AWG 22 through 28
- Use in housing 4.00 mm. pitch 3520 series
- Dual beam contact with tin plated locking lance
- Maximum insulation diameter 1.60 mm. (0.063")

### Materials

- Contact: Phosphor bronze tin plated
- Operating temperature -25°C to +85°C

### Electrical Features

- Current rating: < 1 A
- Contact resistance: < 10 mΩ

### Mechanical Features

- Durability: 25 cycles
- Wire pull-out force:
  - 5.00 Kgf 22 AWG
  - 3.00 Kgf 24 AWG
  - 2.00 Kgf 26 AWG
  - 1.30 Kgf 28 AWG

### Dimensional Information

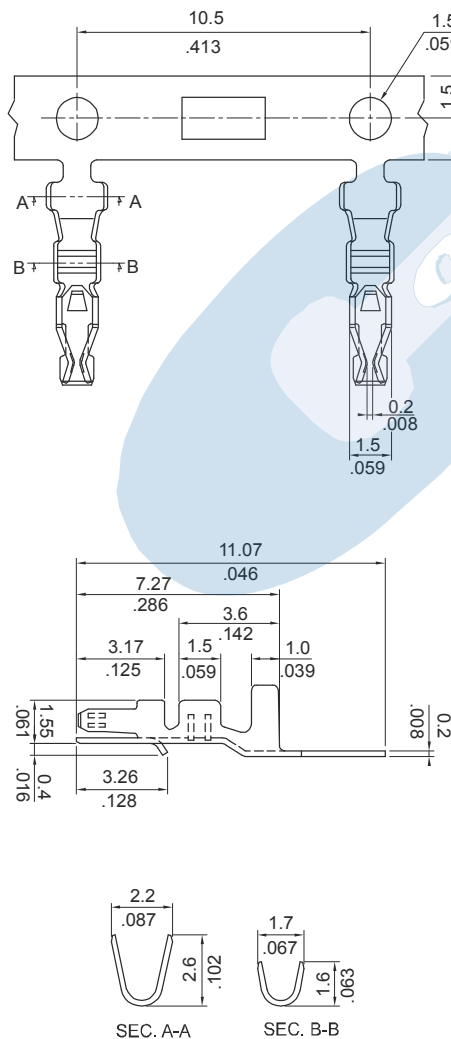

**3524 - T- 00- E**

1

2

#### 1. Terminal Series

#### 2. (T) Contact Plating

- T = 2. Tin plated

#### 2. (E) Packing Options

- E = 0. Chain
- E = 1. Loose Piece