

# CRIMP TERMINAL



## 2870 SERIES. 2.54 mm. (0.100 ") Pitch housing.

### General Features

- Accommodates wire range AWG 22 through 28
- Use in housing 2.54 mm pitch 2866 and 2642 series
- Dual Beam box contact with locking lance
- Maximum insulation diameter 1.70 mm (0.067")

### Materials

- Contact: Phosphor bronze tin pre-plated
- Operating temperature -40°C to +85°C
- RoHS compliant

### Dimensional Information

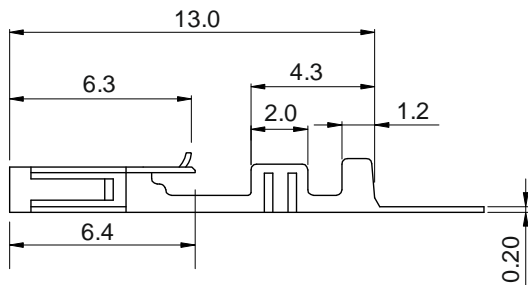
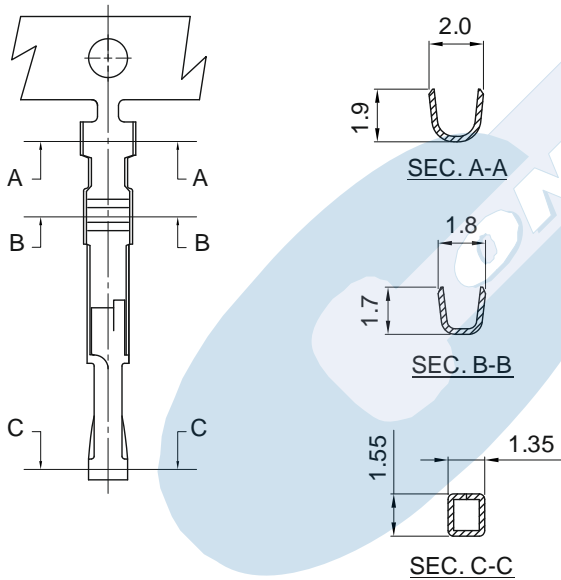

### Electrical Features

- Current rating: < 3 A
- Contact resistance: < 20 mΩ

### Mechanical Features

- Durability: 25 cycles
- Wire pull-out force:
  - 4.00 Kgf 22 AWG
  - 3.00 Kgf 24 AWG
  - 2.00 Kgf 26 AWG
  - 1.00 Kgf 28 AWG

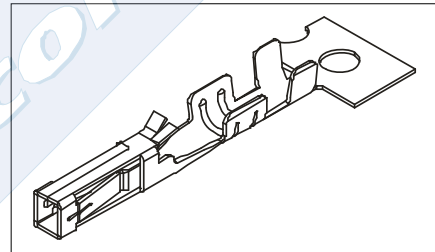

### Part Number:

**2870 - T- 00- E**  
1 2

#### 1. Terminal Serie

#### 2. (T) Contact Plating

- T = 2. Tin plated

#### 2. (E) Packing Options

- E = 0. Chain
- E = 1. Loose Piece