

# DIN 41612 FEMALE C/2 TYPE PRESS FIT



## 2330P SERIES. Female Vertical PCB Type.

### General Features

- Available in 16 (A row), 16 (A+C rows), 24 (A+B+C rows), 32 (A+B rows), 32 (A+C rows) and 48 (A+B+C rows)
- Mates with male C/2 Type 2237, male R/2 type 2331 series and male IDC flat cable 2320 series
- Different tail length in PCB area
- Dual beam contact
- Different selective gold plating in contact and tail area

### Materials

- Insulator: PBT+GF UL 94 V-0
- Contact: Phosphor bronze
- Operating temperature: -40°C to + 85°C
- RoHS compliant

### Dimension information

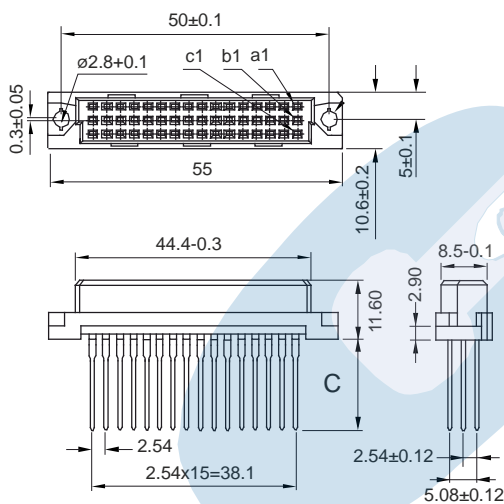

RECOMMENDED HOLE SPECIFICATIONS  
Section A-A

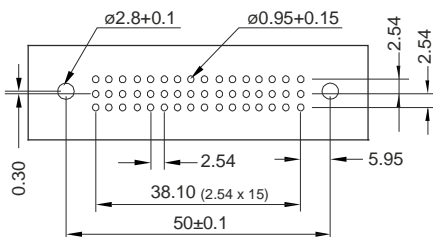
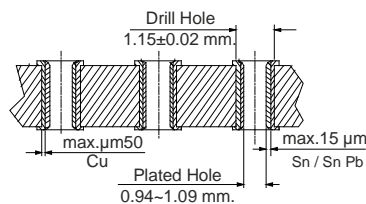

RECOMMENDED PCB HOLE LAYOUT

### Electrical Features

- Voltage rating: < 250 V
- Current rating: < 2A 20 °C; 1A 70 °C; 0.50 A 100 °C
- Contact resistance: < 20 mΩ
- Dielectric Withstanding Voltage: 1000 V AC/minute
- Insulation Resistance: >1000 MΩ
- Capacitance: < 2 pF at 1KHz

### Mechanical Features

- Insertion force receptacle / plug: < 0.09 Kg/pin
- Unmating force receptacle / plug: : >0.03 Kg/pin
- Durability: 50 cycles min. according gold plating thickness

### Ordering Information:

**2330P-**   **T-**   **XX-**   **C**  
 1            2            3            4

#### 1. Connector Series

#### 2. (T) Contact Plating

- T = 2. Tin plated
- T = 3. Selective gold flash plating contact area
- T = 4. 15 µ" selec. gold plating contact area
- T = 5. 30 µ" selec. gold plating contact area
- T = 33. Sel. gold flash plating cont. and tail area
- T = 44. 15 µ" Sel. gold flash plat. cont. and tail area
- T = 55. 30 µ" sel. gold flash plat. cont. and tail area

#### 3. (XX) Circuits Configuration

- 16. For 16 circuits (A+C rows) even contacts
- 32. For 32 circuits (A+C rows)
- 48. For 48 circuits (A+B+C rows)

#### 4. (C) Tail Options

- 5. PCB tail 0.60x0.60 (5.00 mm.)
- 3. Wrapping 0.60x0.60 (13.00 mm.)
- 7. Wrapping 0.60x0.60 (17.00 mm.)
- 8. Wrapping 0.64x0.64 (13.00 mm.)
- 9. Wrapping 0.64x0.64 (17.00 mm.)