

DUAL ROW TOP ENTRY SMT SOCKET



1302 SERIES. 1.27 x 1.27 mm (0.050" x 0.050") pitch.

General Features

- Available in 4 through 100 circuits
- Mates with pin headers 1.27 mm pitch 1304 & 1306
- Accept 0.40 square pin. 4.60 mm high
- Dual beam contact with different plating
- With fixing post for alignment connector pins

Materials

- Insulator: Polyester LCP UL 94 V-0
- Contact: Phosphor bronze
- Operating temperature: -40°C to +105°C
- RoHS Compliant

Dimension Information

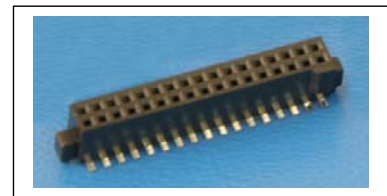
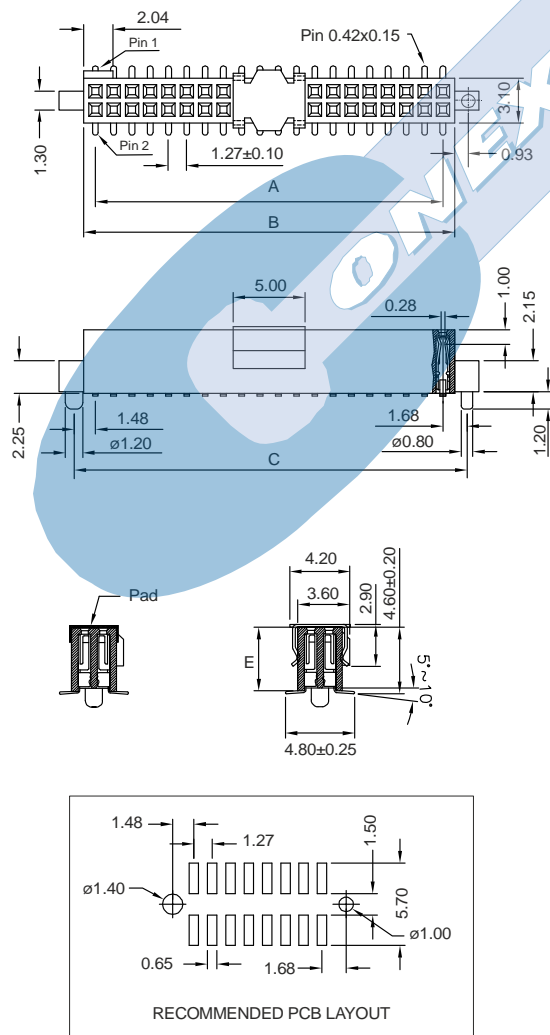

1302 - T- XX- P- E
 1 2 3 4 5

1. Series

2. Plating Options

- T = 2. Tin plated
- T = 3. Gold flash over nickel.
Recommended Finish
- T = 5. 15µ" gold over nickel
- T = 6. 30µ" gold over nickel

3. Number of circuits

- Available in 4 through 100 circuits
(For 100 circuits replace XX for 00)

4. Fixing System

- P = 1. With fixing post

5. Packing Options

- E = 1. Tube + Pad
- E = 2. Reel + Pad
- E = 3. Tube + Film
- E = 4. Reel + Film
- E = 5. Tube + Metallic Pad
- E = 6. Reel + Metallic Pad

DIMENSIONS:

$$A = 1.27 \left(\frac{XX}{2} - 1 \right) \quad B = 1.27 \left(\frac{XX}{2} \right) + 0.35 \quad C = 1.27 \left(\frac{XX}{2} \right) + 1.88$$

XX = Number of circuits