

# CRIMP TERMINAL



## 1216 SERIES. 1.25 mm. (0.049") Pitch housing

### General Features

- Accommodates wire range AWG 28 through 32
- Use in housing 1.25 mm pitch 1215 series
- Tin plated dual beam contact with locking lance
- Maximum insulation diameter 1.00 mm (0.039")

### Materials

- Contact: Phosphor bronze
- Operating temperature -40°C to +85°C

### Electrical Features

- Current rating: < 1 A
- Contact resistance: < 20 mΩ

### Mechanical Features

- Durability: 25 cycles
- Wire pull-out force:
  - < 1.00 Kgf 28 AWG
  - < 0.50 Kgf 30 AWG
  - < 0.30 Kgf 32 AWG

### Dimensional Information

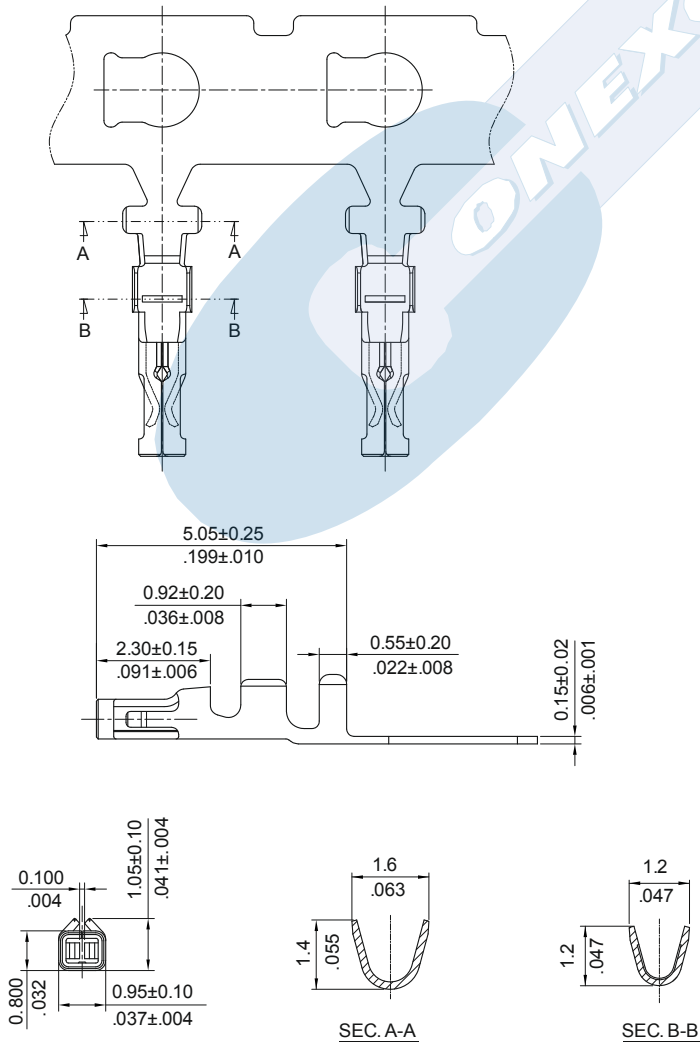

**1216 - 2- 00- E**  
 1 2

### 1. Terminal Serie

### 2. (E) Packing Options

- E = 0. Chain
- E = 1. Loose Piece