

CRIMP TERMINAL



1206 SERIES. 1.25 mm. (0.039") Pitch housing

General Features

- Accommodates wire range AWG 26 through 30
- Use in housing 1.00 mm pitch 1205 series
- Tin plated dual beam contact with locking lance
- Maximum insulation diameter 1.00 mm (0.039")

Materials

- Contact: Phosphor bronze
- Operating temperature -40°C to +85°C

Dimensional Information

Electrical Features

- Current rating: < 1 A
- Contact resistance: < 30 mΩ

Mechanical Features

- Durability: 25 cycles
- Wire pull-out force:
2.00 Kg 26 AWG
1.00 Kg 28 AWG
0.50 Kg 30 AWG

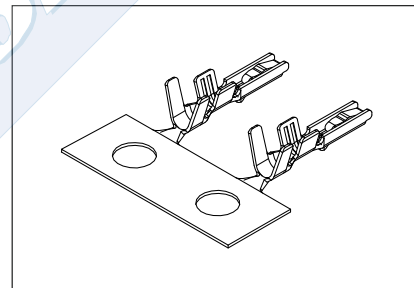
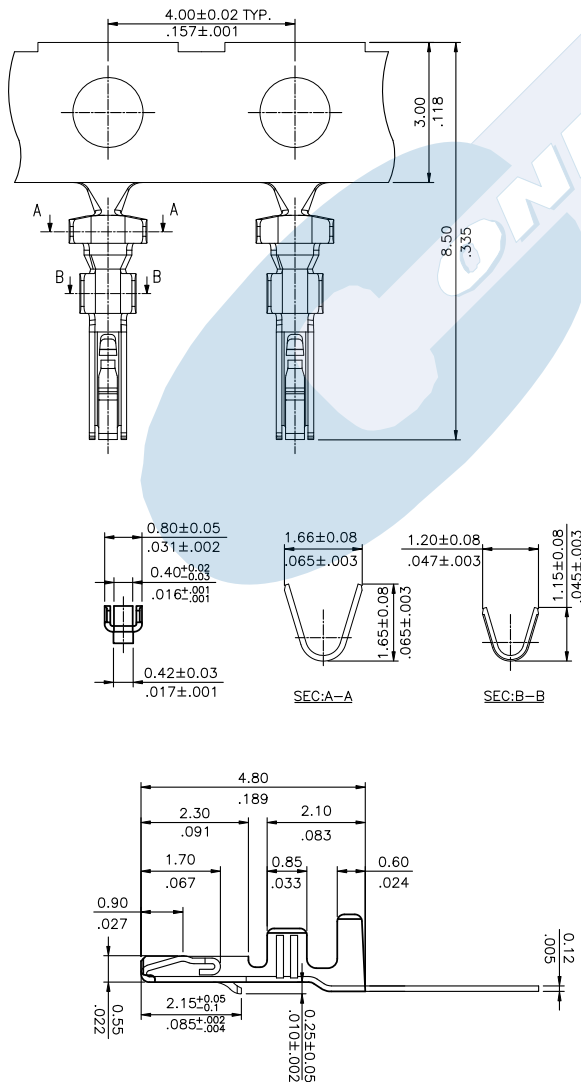

1206 - 2- 00- E
1 2

1. Terminal Serie

2. (E) Packing Options

- E = 0. Chain
- E = 1. Loose piece

