

0.50 mm. FCC/FPC SIDE ENTRY ZIF SMT CON.



0531 SERIES. 0.50mm (0.020") Pitch.

General Features

- Available in 10, 12 and 40 circuits
- Zero insertion force (ZIF) and high retention force
- Accept 0.30 mm thickness FPC
- Downside contact. 1.75 mm. high.
- Easy for FPC installation and reliable operation
- With metal fixed SMT tabs to secure connector on PCB

Materials

- Body: High temperature plastic UL 94 V-0
- Slider: High temperature plastic UL 94 V-0
- Contact: Phosphor bronze; Fixed tab: Brass
- Operating temperature. -40°C to + 85°C
- RoHS compliant

Electrical Features

- Voltage rating: < 50 V
- Current rating: < 0.50 A
- Contact resistance: < 30 mΩ
- Dielectric Withstanding Voltage: 250 V AC/minute
- Insulation Resistance: >100 MΩ

Mechanical Features

- Contact retaining force in insulator: > 0.10 Kgf
- FPC withdrawal force: > 0.03 Kgf/contact
- Durability: 20 cycles

Materials

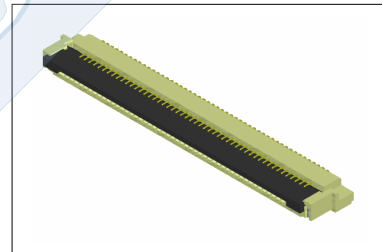
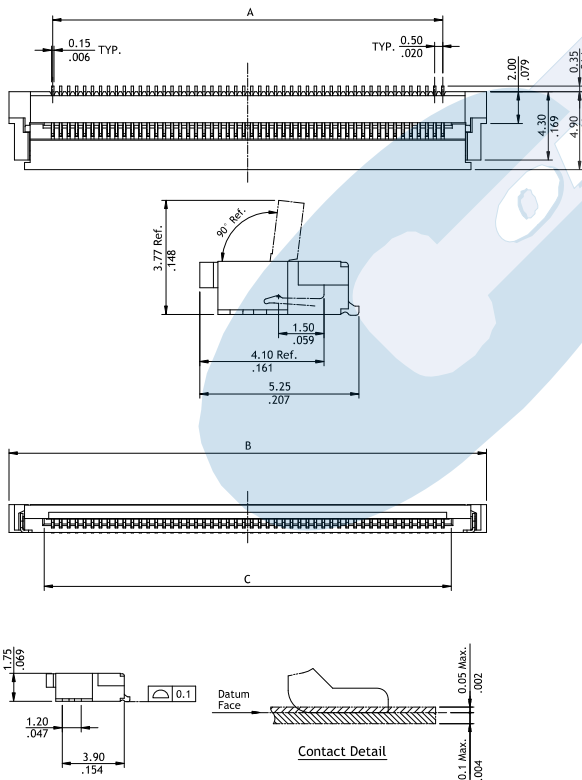

Ordering Information:

0531 - 2- XX- E
 1 2 3 4

1. Connector Series

2. (T) Contact Plating

- T = 2. Tin plated

3. (XX) Number of circuits

- Available in 10, 12 and 40 circuits

4. (E) Packing Options

- E = 1. Tube
- E = 2. Reel + Pad

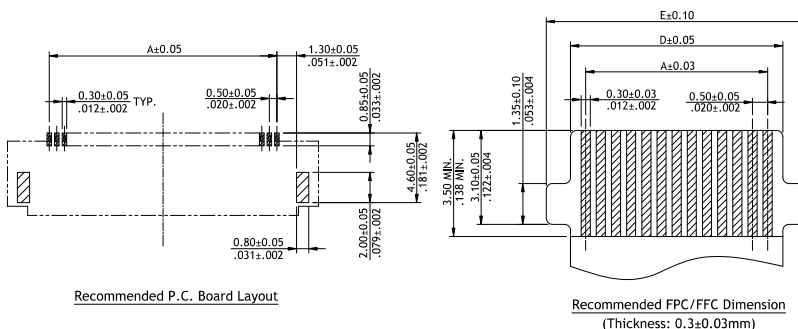

DIMENSIONS:

- A = 0.50 x (xx-1)
- B = A + 5.50
- C = A + 1.07
- D = A + 1.0
- E = A + 2.60

*(XX) = Circuits (10, 12 and 40)