

SINGLE ROW STRAIGHT HEADER SMT



2150 SERIES. 2.00mm(0.079"). SMT

Features

- Available in 3 through 40 circuits
- Mates with 2.00mm single row housing and socket
- Insulator Material: Polyester UL 94V-0. Nylon 6T
- 0.50mm square pin in copper alloy

- Different pin length and plating options are available
- Two different pin configuration
- For other options consult the Sales Office

Dimensional Information

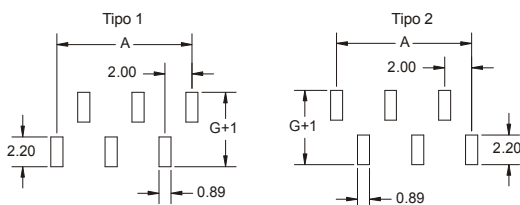
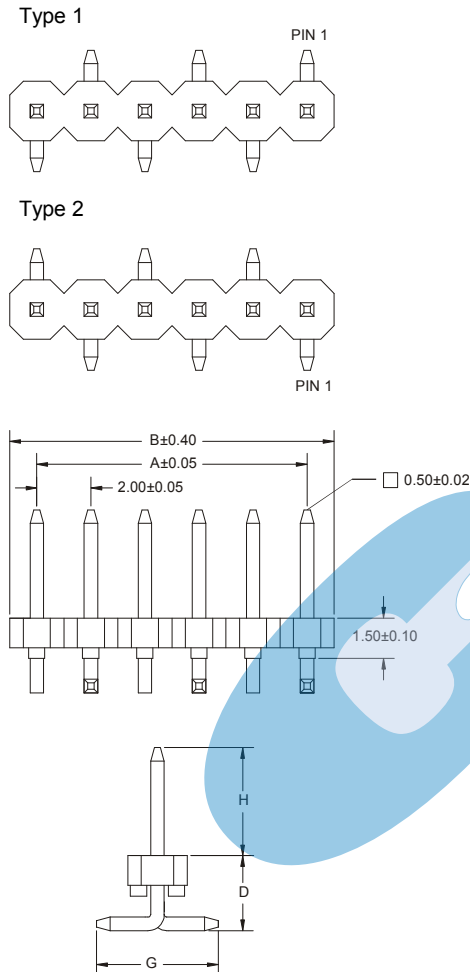

Recommended PCB Layout

Ordering and Dimensional Information

Circuit Size	Part Number		Dimensions	
	Type 1	Type 2	A	B
03	2150-T031CE	2150-T032CE	4,00(0,157)	6,00(0,236)
04	2150-T041CE	2150-T042CE	6,00(0,236)	8,00(0,315)
05	2150-T051CE	2150-T052CE	8,00(0,315)	10,00(0,394)
06	2150-T061CE	2150-T062CE	10,00(0,394)	12,00(0,472)
07	2150-T071CE	2150-T072CE	12,00(0,472)	14,00(0,551)
08	2150-T081CE	2150-T082CE	14,00(0,551)	16,00(0,630)
09	2150-T091CE	2150-T092CE	16,00(0,630)	18,00(0,709)
10	2150-T101CE	2150-T102CE	18,00(0,709)	20,00(0,787)
11	2150-T111CE	2150-T112CE	20,00(0,787)	22,00(0,866)
12	2150-T121CE	2150-T122CE	22,00(0,866)	24,00(0,945)
13	2150-T131CE	2150-T132CE	24,00(0,945)	26,00(1,024)
14	2150-T141CE	2150-T142CE	26,00(1,024)	28,00(1,102)
15	2150-T151CE	2150-T152CE	28,00(1,102)	30,00(1,181)
16	2150-T161CE	2150-T162CE	30,00(1,181)	32,00(1,260)
17	2150-T171CE	2150-T172CE	32,00(1,260)	34,00(1,339)
18	2150-T181CE	2150-T182CE	34,00(1,339)	36,00(1,417)
19	2150-T191CE	2150-T192CE	36,00(1,417)	38,00(1,496)
20	2150-T201CE	2150-T202CE	38,00(1,496)	40,00(1,575)
21	2150-T211CE	2150-T212CE	40,00(1,575)	42,00(1,654)
22	2150-T221CE	2150-T222CE	42,00(1,654)	44,00(1,732)
23	2150-T231CE	2150-T232CE	44,00(1,732)	46,00(1,811)
24	2150-T241CE	2150-T242CE	46,00(1,811)	48,00(1,890)
25	2150-T251CE	2150-T252CE	48,00(1,890)	50,00(1,969)
26	2150-T261CE	2150-T262CE	50,00(1,969)	52,00(2,047)
27	2150-T271CE	2150-T272CE	52,00(2,047)	54,00(2,126)
28	2150-T281CE	2150-T282CE	54,00(2,126)	56,00(2,205)
29	2150-T291CE	2150-T292CE	56,00(2,205)	58,00(2,283)
30	2150-T301CE	2150-T302CE	58,00(2,283)	60,00(2,362)
31	2150-T311CE	2150-T312CE	60,00(2,362)	62,00(2,441)
32	2150-T321CE	2150-T322CE	62,00(2,441)	64,00(2,520)
33	2150-T331CE	2150-T332CE	62,00(2,441)	64,00(2,520)
34	2150-T341CE	2150-T342CE	64,00(2,520)	66,00(2,598)
35	2150-T351CE	2150-T352CE	66,00(2,598)	68,00(2,677)
36	2150-T361CE	2150-T362CE	68,00(2,677)	70,00(2,756)
37	2150-T371CE	2150-T372CE	70,00(2,756)	72,00(2,835)
38	2150-T381CE	2150-T382CE	72,00(2,835)	74,00(2,913)
39	2150-T391CE	2150-T392CE	74,00(2,913)	76,00(2,992)
40	2150-T401CE	2150-T402CE	76,00(2,992)	78,00(3,071)

T = Contact Plating

- T = 3. Gold flash over 50µ" nickel (Recommended Finish)
- T = 13. Selective gold flash over 50µ" nickel
- T = 14. 15µ" selective gold over 50µ" nickel
- T = 16. 30µ" selective gold over 50µ" nickel

C = Pin Length

- C = 1. Dim. H = 4.00; D = 2.77 ; G = 4.50 mm.
- C = 2. Dim. H = 4.00; D = 2.85 ; G = 3.35 mm.
- C = 7. Dim. H = 9.00; D = 2.77 ; G = 4.50 mm.

E = Packing Options

- E = 1. Tube + Pad

For other options consult to Sales Office