

MALE STRAIGHT HEADER EXTRACTOR SMT



1553 SERIE. 1.27 x 2.54 mm. (0.050 x 0.100"). For PCB solder

Features

- Available in 10, 20, 26, 30, 34, 40, 50, 60, 68, 70, 80, 90 and 100 circuits
- Insulator material: Polyester glass filled UL 94V-0
- 0.46 mm square pin in phosphor bronze with different plating options
- Mates with female header series 1541
- Available with short or long type extractors
- Fully shrouded. Provides fast connection / disconnection of Flat cable assembly

Dimensional information:

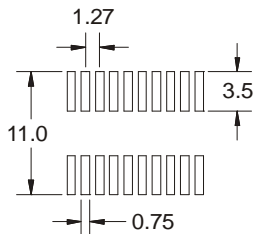
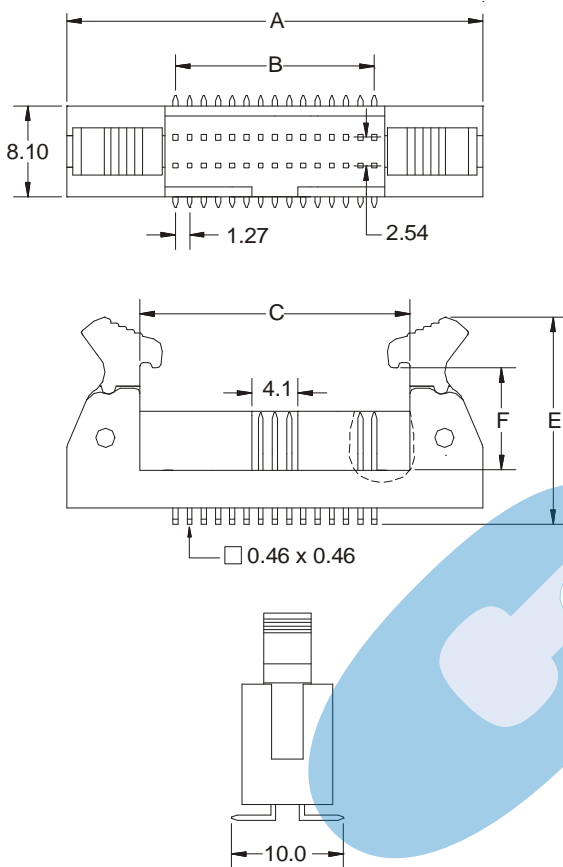

RECOMMENDED PCB LAYOUT

Ordering and dimensional information:

Circuit Size	Part Number	Dimensions		
		A	B	C
10	1553-T10X	24.50 (0.964)	5.08 (0.200)	11.46 (0.451)
20	1553-T20X	30.85 (1.214)	11.43 (0.450)	17.81 (0.701)
26	1553-T26X	34.66 (1.364)	15.24 (0.600)	21.62 (0.851)
30	1553-T30X	37.20 (1.464)	17.78 (0.700)	24.16 (0.951)
34	1553-T34X	39.74 (1.564)	20.32 (0.800)	26.70 (1.051)
40	1553-T40X	43.55 (1.714)	24.13 (0.950)	30.51 (1.201)
50	1553-T50X	49.90 (1.964)	30.48 (1.200)	36.86 (1.451)
60	1553-T60X	56.25 (2.214)	36.83 (1.450)	43.21 (1.701)
68	1553-T68X	61.33 (2.414)	41.91 (1.650)	48.29 (1.901)
70	1553-T70X	62.60 (2.464)	43.18 (1.700)	49.56 (1.951)
80	1553-T80X	68.95 (2.714)	49.53 (1.950)	55.91 (2.201)
90	1553-T90X	75.30 (2.965)	55.88 (2.200)	62.26 (2.451)
100	1553-T00X	81.85 (3.222)	62.23 (2.450)	68.61 (2.701)

T = Contact Plating

- T = 2. Tin plated.
- T = 3. Gold flash over 50µ" nickel
Recommended Finish
- T = 5. 15µ" gold over 50µ" nickel
- T = 6. 30µ" gold over 50µ" nickel

X = Extractor type

- X = 1. Short. For use without strain relief
- X = 2. Long. For use with strain relief

DIMENSIONS	E	F
Short expulsor	17.00	8.00
Lenght expulsor	18.50	10.65

