

MULTI CONTACT CRIMP TERMINAL



2653 SERIES. 2.54mm(0.100"). Lateral Latch

Features

- Material: Phosphor bronze tin or selective gold plated
- Can be used in 2651 and 2652 series housing
- Accommodates wire range AWG 22 through 28
- Maximum insulation 1.70mm(0.067") diameter
- Twinleaf boxed shape terminal.
- Mates with 0.64mm(.025") square pin

Dimensional Information

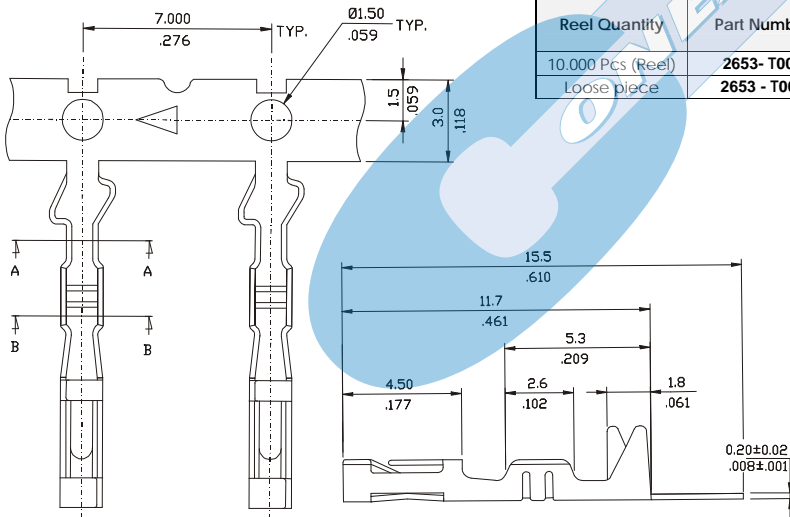

Ordering and Dimensional Information

Reel Quantity	Part Number	Material	Wire Ranges	Insulation Diameter
10,000 Pcs (Reel)	2653- T000	Phosphor Bronze	AWG 22 – 28	1.70 (.067") Max.
Loose piece	2653 - T001	Phosphor Bronze	AWG 22 – 28	1.70 (.067") Max.

T = Contact Plating

- T = 2. Tin plated.
- T = 3. Gold flash over 50µ" nickel.

